

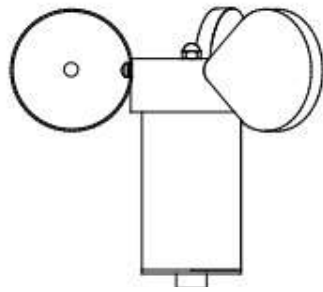

**TV-4
TV-4-A
Wind Speed Sensor
User's Manual**



Model TV-4 Wind Speed Sensor

DESCRIPTION

The Texas Electronics, Inc. TV-4 Wind Speed Sensor is a mechanical style anemometer that measures the horizontal velocity of wind. This unit combines small physical size with superior bearings to meet the EPA's Prevention of Significant Deterioration (PSD) starting threshold requirements.

The TV-4 wind speed sensor is a freestanding device for measuring air velocity. The sensor consists of a lightweight 3-cup anemometer, which electromechanically converts wind speed into a measurable electronic signal.

The output signal can be presented in 3 optional forms: a pulsed DC signal, an AC frequency, or a conditioned analog signal. Each output has a specific application. The pulsed DC signal is used where high-accuracy is required and continuous power is not an issue. The AC frequency output is used in situations where power consumption is critical. Finally, the conditioned analog signal is used to easily and quickly communicate with virtually all digital control systems such as PLC or SCADA systems.

SPECIFICATIONS

	<u>TV-4</u>	<u>TV-4-A</u>
Operating Range:	0-100 mph	0-100 mph
Signal Presentation:	Pulsed DC output - light chopper	Analog 4-20 mA
		4 mA = 0 MPH 20 mA = 100 MPH
Pulsed DC output:	20-slot disc 1 MPH = 520 pulses/min. 100 MPH = 52000 pulses/min. (Other voltages available upon request)	20-slot disc 1 MPH = 520 pulses/min. 100 MPH = 52000 pulses/min. (Other voltages available upon request)
Input Power:	+5.0 VDC @ 5mA (typical)	10 - 36 VDC
Performance:		
Accuracy: +/- 2.0 mph (0.89 m/s)	+/- 2.0 mph (0.89 m/s)	
Distance Constant:	> 21.7' (6.6 m)	>21.7' (6.6 m)
Starting Threshold:	0.6 mph (0.27 m/s)	0.6 mph (0.27 m/s)
Environmental:		
Operational Envelope:	0-135 mph (0 to 60 m/s)	0-135 mph (0 to 60 m/s)
Temperature:	-40 to 160° F (-40 to 70° C)	-40 to 160°F (-40 to 70°C)
Relative Humidity:	0-100%	0 to 100%

Physical:	
Cup Wheel Diameter:	6.0" (15.3 cm)
Overall Height:	4.75" (12.1 cm)
Turning Radius:	3.0" (7.6 cm)
Cup Diameter:	2.0" (5.1 cm)
Bearings:	APEC 3 or better
Mounting Base:	Screw attachment, 10-32 machine screw
Weight:	0.5 lbs (0.23 kg) less cable
Cable:	60', 22 Gauge 3 conductor
Warranty:	3 years

FEATURES & BENEFITS

- Superior low starting threshold due to small physical size
- No plastic parts for extremely long life
- Precision stainless steel bearings for stability and repeatability
- Crossarm included with purchase of matching wind direction sensor
- Easy installation and maintenance
- Over 5 years in production
- Lightweight and rugged anodized aluminum exterior

INSTALLATION & MAINTENANCE

Installation consists of threading the 10-32 mounting base into our crossarm or any other suitable beam. If a crossarm is used, the entire unit can be bolted to a mast or attached via U-bolts.

The sensor is dynamically calibrated at the factory and due to the nature of its operation should not require field calibration. Field maintenance should include occasional cleaning of the cup assembly and inspection of the internal mechanism to make sure it is free from insects and debris. In some applications, users may need to occasionally verify and document sensor accuracy with a synchronous test motor. Other possible routine maintenance involves replacing the bearing housing assembly every three to five years to maintain low starting threshold.

ORDERING INFORMATION

Model #	Description
TV-4	Wind Speed Sensor, Light Industrial (Specify supply voltages other than 5 VDC)
TV-4-A	Wind Speed Sensor, Analog 4-20 mA

**Sensor is designed to work with TD-4 wind direction sensor.*

Optional Parts / Accessories

PROPER EXPOSURE OF METEOROLOGICAL INSTRUMENTS

The following generally recognized guidelines depict ideal sensor mounting locations. These guidelines are only suggestions to aid the user in selecting optimum representative sampling locations for a particular sensor.

Reference was made to US Weather Bureau Installation criteria in preparing this data (See Reference 1).

WIND EQUIPMENT:

So far as available sites permit, wind sensors should be placed above the ground on a freely-exposed tower (20 feet or higher) and over terrain that is relatively level and free from obstructions to wind flow. When a compromise must be made, sensing units should be exposed at least 12 feet above any obstruction within 100 feet and at least as high as any obstruction within 100 to 200 feet of the wind equipment. Support towers or masts should not be of such bulk or shape as to create an appreciable obstruction to wind flow. Avoid sites where local obstructions may create up-or-down drafts, eddy currents or jet-flow effects. When sensors are roof-mounted, they should be installed at least 10 feet (or more) from the roof surface, depending upon the particular installation site. Turbulence and other local effects can be reduced somewhat by mounting sensors on the upwind end of the building (the end of the building exposed to the most common local prevailing winds). Horizontal-mount booms that extend from existing towers should be fabricated so that sensors will extend a distance of 5 to 10 feet from the tower assembly (dependent on tower thickness).

Wind direction sensors are oriented upon installation in reference to either true north or magnetic north. True north is obtained by applying a local magnetic variation correction factor to a magnetic north compass indication (magnetic variation for a particular locality is obtainable from the nearest Weather Bureau Branch Office). Indicator readings for a true north sensor orientation will then be in terms of true geographic compass points. All U.S. Weather Bureau surface wind data used for observational network reporting purposes and general public use is given in reference to this true north format. Indicator readings for a magnetic north sensor orientation will be in terms of actual readings as would be obtained from directly viewing a magnetic compass instrument. Wind direction data at Federal Aviation Agency and other aircraft reporting facilities (for direct control tower-to-pilot utilization) is always made in reference to this magnetic north format.

WIRING DIAGRAM

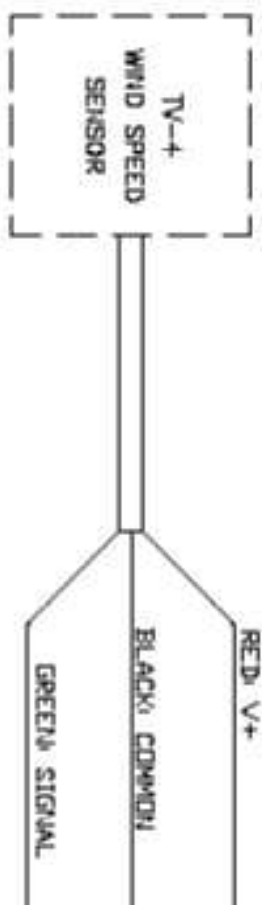

TYPICAL RANGE
0-100 MPH

OUTPUT
100 MPH = 52k pulses/min

Texas Electronics, Inc.
The Gold Standard in Weather Instrumentation Since 1957



TITLE
TV-4 WIND SPEED WIRING DIAGRAM

SIZE	FSCH NO.	DWG NO.	REV
A		3024	A
SCALE		SHEET	1-1

WIRING DIAGRAM

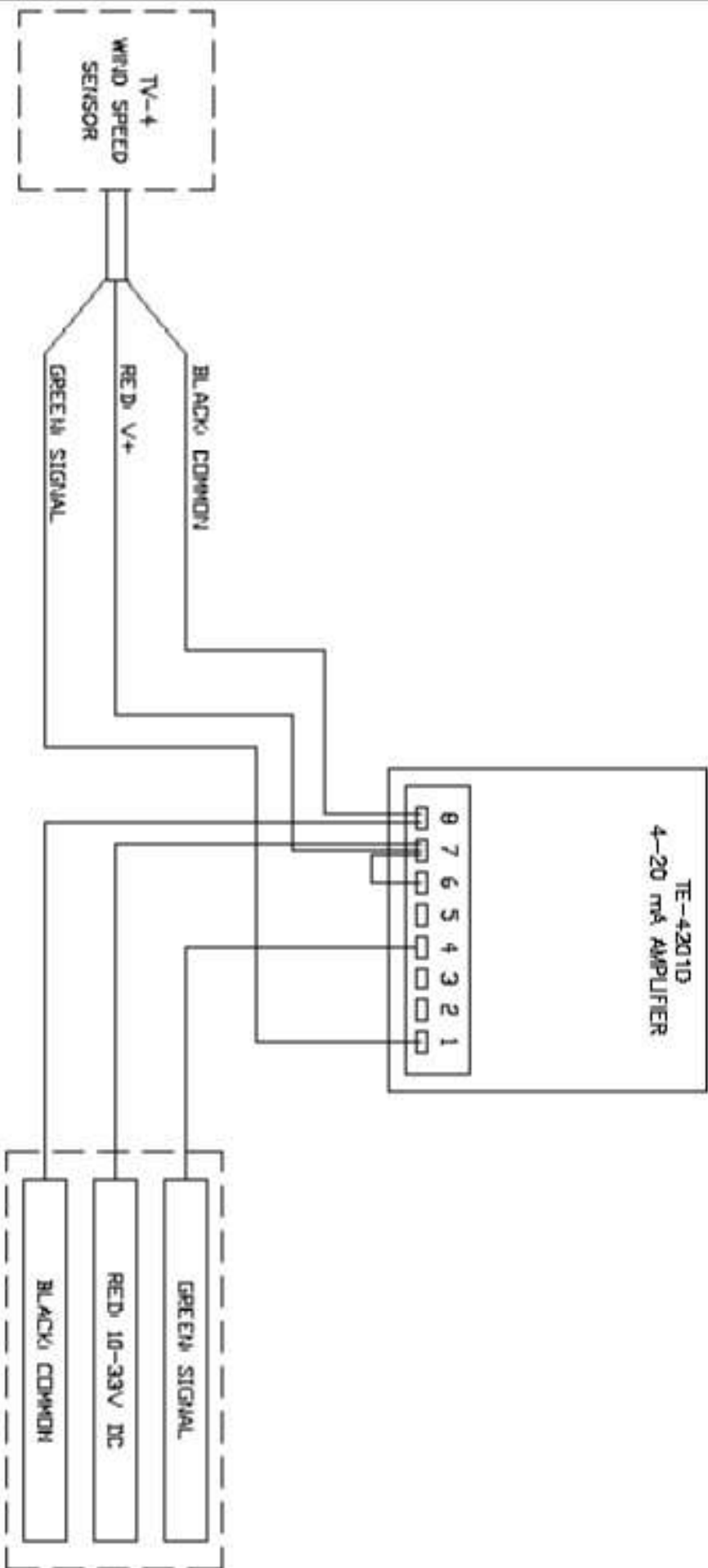

TYPICAL RANGE
0-100 MPH

OUTPUT
4 to 20 mA

Texas Electronics, Inc.			
<small>The Gold Standard in Weather Instrumentation Since 1967</small>			
			
<u>TITLE</u>		TV-4A WIND SPEED SENSOR	
<u>SIZE</u>	<u>FORM NO.</u>	<u>DRG NO.</u>	<u>REV</u>
A		3023	A
<u>SCALE</u>			<u>SHEET</u> 1-1

WIRING DIAGRAM

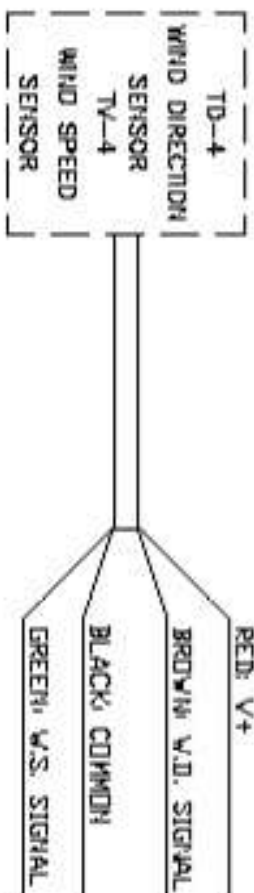

TYPICAL RANGE

WIND DIRECTION: 0-360° Mechanical, 5K OHM: 0-355° Elect., 10K OHM: 0-357° Elect.

WIND SPEED: 0-100 MPH

OUTPUT

WIND DIRECTION: 10K OHM POTENTIOMETER

WIND SPEED: 100 MPH = 52k pulses/min

Texas Electronics, Inc.
The Gold Standard in Weather Instrumentation Since 1957



TITLE		TD-4 WIND DIRECTION &	
SIZE		TV-4 WIND SPEED WIRING DIAGRAM	
A	FROM I.D.	DATE I.D.	REV
		3020	A
SHEET			1-1

WIRING DIAGRAM

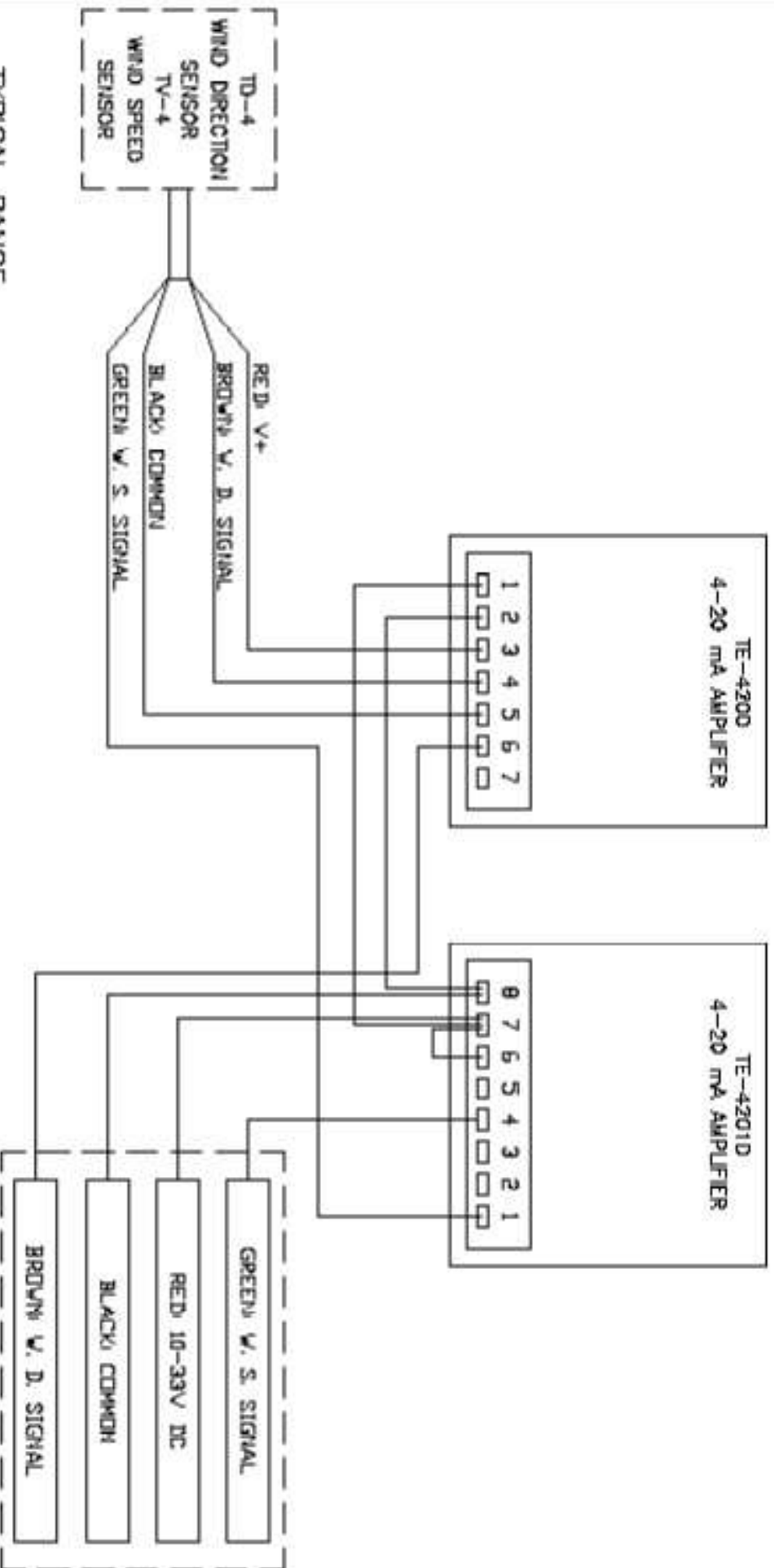

TYPICAL RANGE
 WIND DIRECTION: 0-355° ELECTRICAL, 360° MECH.
 WIND SPEED: 0-100 MPH

OUTPUT
 4 to 20 mA

Texas Electronics, Inc.			
The Gold Standard in Weather Instrumentation Since 1957			
			
TITLE		TD-4A WIND DIRECTION & TV-4A WIND SPEED	
SIZE	FORM NO.	DWG NO.	REV
A		3019	A
SCALE	SHEET 1-1		

Warranty

Texas Electronics, Inc. (hereafter TEI) warrants the equipment manufactured by it to be free from defects in material and workmanship. Upon return, transportation charges prepaid to TEI, within three (3) years of original shipment of sensors and one (1) year of original shipment of electronics, recorders and indicators, TEI will repair or replace, at its option, any equipment which it determines to contain defective material or workmanship, and will return said equipment to purchaser, F.O.B., TEI. Texas Electronics shall not be obligated however to repair or replace equipment which has been repaired by others, abused, improperly installed, altered or otherwise misused or damaged in any way. TEI will not be responsible for any dismantling, re-assembly, or reinstallation charges.

This warranty is in lieu of all other warranties, expressed or implied. TEI shall not be liable for any special, indirect, incidental or consequential damages claimed in connection with any rescission of this agreement by purchaser.