



TR-525 Series Rainfall Sensors User's Manual

Models:

TR-525I (6")

TR-525U (8")

TR-525M (9.66")

TR-525W2 (200mm)

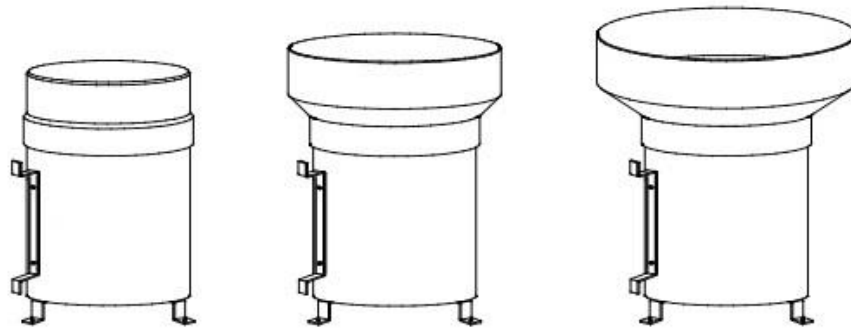

Model TR-525 Series Rainfall Sensors

DESCRIPTION

The sensor consists of a gold powder-coated aluminum collector funnel with a knife-edge that diverts the water to a tipping bucket mechanism. A magnet is attached to the tipping bucket, which actuates a magnetic switch on each tip of the bucket. The water drains out of the bottom of the housing, so the sensor requires no attention or servicing. Connecting the sensor to an event counter on a data logger or display module allows for electronics record keeping of accumulated rainfall.

The aluminum housing is finished with a white powder-coat to withstand years of exposure to the environment.

Specifications

TR-525I

TR-525U

TR-525M

TR-525W2

Resolution:	0.01" or .2 mm	0.01" or .2 mm	0.1 mm	0.01" or .2 mm
Accuracy:	0-2 in. (50 mm) per hour; +/-1%	0-2 in. (50 mm) per hour; +/-1%	50 mm per hour; +/-1%	0-2 in. (50 mm) per hour; +/-1%
Range:	27" (700 mm per hour)	27" (700 mm per hour)	27" (700 mm per hour)	27" (700 mm per hour)
Average Switch Closure Time:	135 ms	135 ms	135 ms	135 ms
Maximum Bounce Settling Time:	0.75 ms	0.75 ms	0.75 ms	0.75 ms
Maximum Switch Rating:	30 VDC @ 2A 115 VAC @ 1A	30 VDC @ 2A 115 VAC @ 1A	30 VDC @ 2A 115 VAC @ 1A	30 VDC @ 2A 115 VAC @ 1A
Temperature Limits:				
Operational Temperature:	32 to 158°F	32 to 158°F	32 to 158°F	32 to 158°F
Storage Temperature:	-40 to 185°F	-40 to 185°F	-40 to 185°F	-40 to 185°F
Humidity Limits:	0 to 100%	0 to 100%	0 to 100%	0 to 100%
Height:	10.25"	11.125"	12"	11.125"
Weight:	1.6 lbs.	1.8 lbs.	2 lbs.	1.8 lbs.
Receiving Orifice Diameter:	6.060"	8.000"	9.664"	200mm
Cable:	10' 24 Gauge 2 Cnd.	10', 24 Gauge 2 Cnd.	10', 24 Gauge 2 Cnd.	10', 24 Gauge 2 Cnd.
Maintenance:	Occasional cleaning of debris from filter screen may be required.	Occasional cleaning of debris from filter screen may be required.	Occasional cleaning of debris from filter screen may be required.	Occasional cleaning of debris from filter screen may be required.
Warranty:	3 years	3 years	3 years	3 years

ORDERING INFORMATION

Model #	Description: Calibration options .01 inch, .10mm, .20mm
TR-525I	Rain Gauge 6.06" collector
TR-525U	Rain Gauge 8.00" collector
TR-525M	Rain Gauge 9.66" collector
TR-525W2	Rain Gauge 200mm collector

Optional Parts / Accessories

HOBO	Pendant Datalogger
MB-525	Pole Mounting Base
FC-500	Field Calibration Kit
BB-525	Bird Repellant
HT-525	Heater, 120 VAC

MODEL 525 MOUNTING EXAMPLES

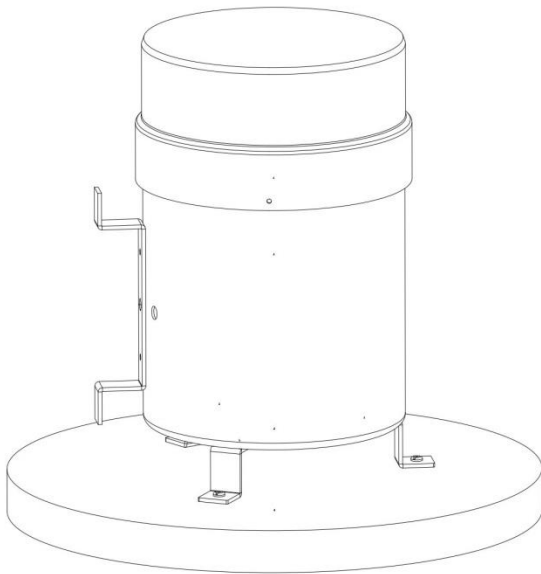

Model 525 Surface Mounted On a Masonry Block

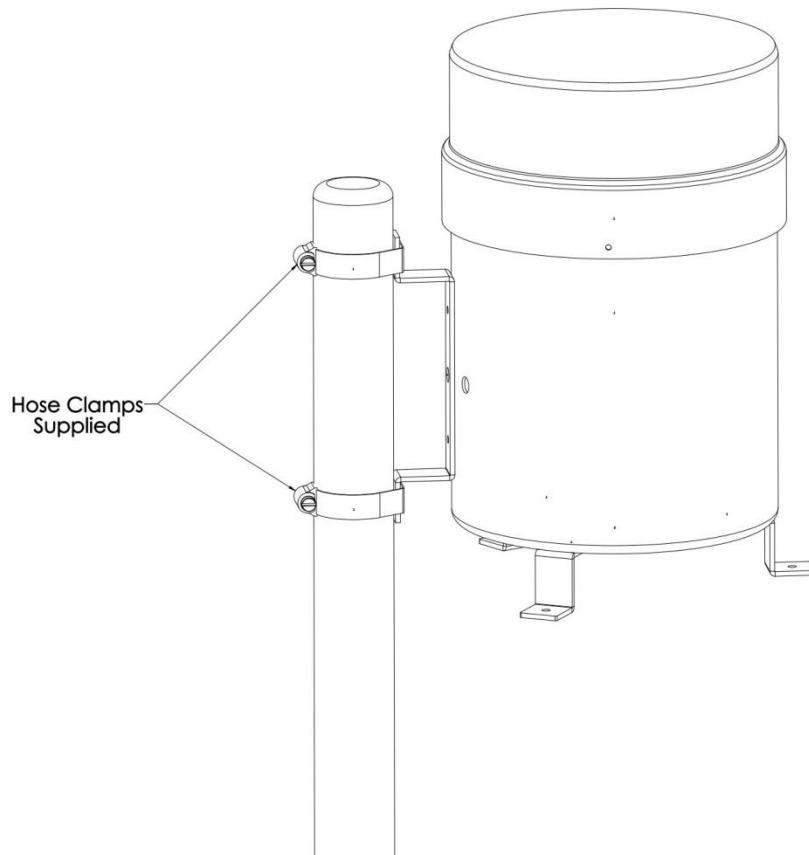

Hose Clamps
Supplied

Model 525 Mast Mounted

MODEL 525

TIPPING BUCKET RAIN GAUGE TRANSMITTER

INSTALLATION INSTRUCTIONS

A clear and unobstructed mounting location is necessary to obtain accurate rainfall readings.

This transmitter is designed to be mounted two ways, by surface mounting or mast mounting. Surface mounting is recommended whenever possible. The transmitter housing must be mounted in a level position and in a location free from vibration. If mast mounted, make sure that the mast is properly guyed so that vibration in high winds is kept to a minimum.

THE FOLLOWING IS VERY IMPORTANT:

After transmitter installation, remove the gold funnel and observe the black tipping bucket. It should not be held in a dead center position by the magnetic attraction of the bucket magnet and the magnetic switch. Press either end of the bucket down against the stop to be sure it is not centered.

The connecting cable between transmitter and indicator can be shortened or lengthened as required.

The funnel and tipping bucket mechanism should be cleaned periodically. An accumulation of dirt, bugs, etc. on the tipping bucket will adversely affect the calibration.

REMOVE AND USE THIS TEMPLATE TO BASE MOUNT THE RAINFALL SENSOR

MOUNTING TEMPLATE

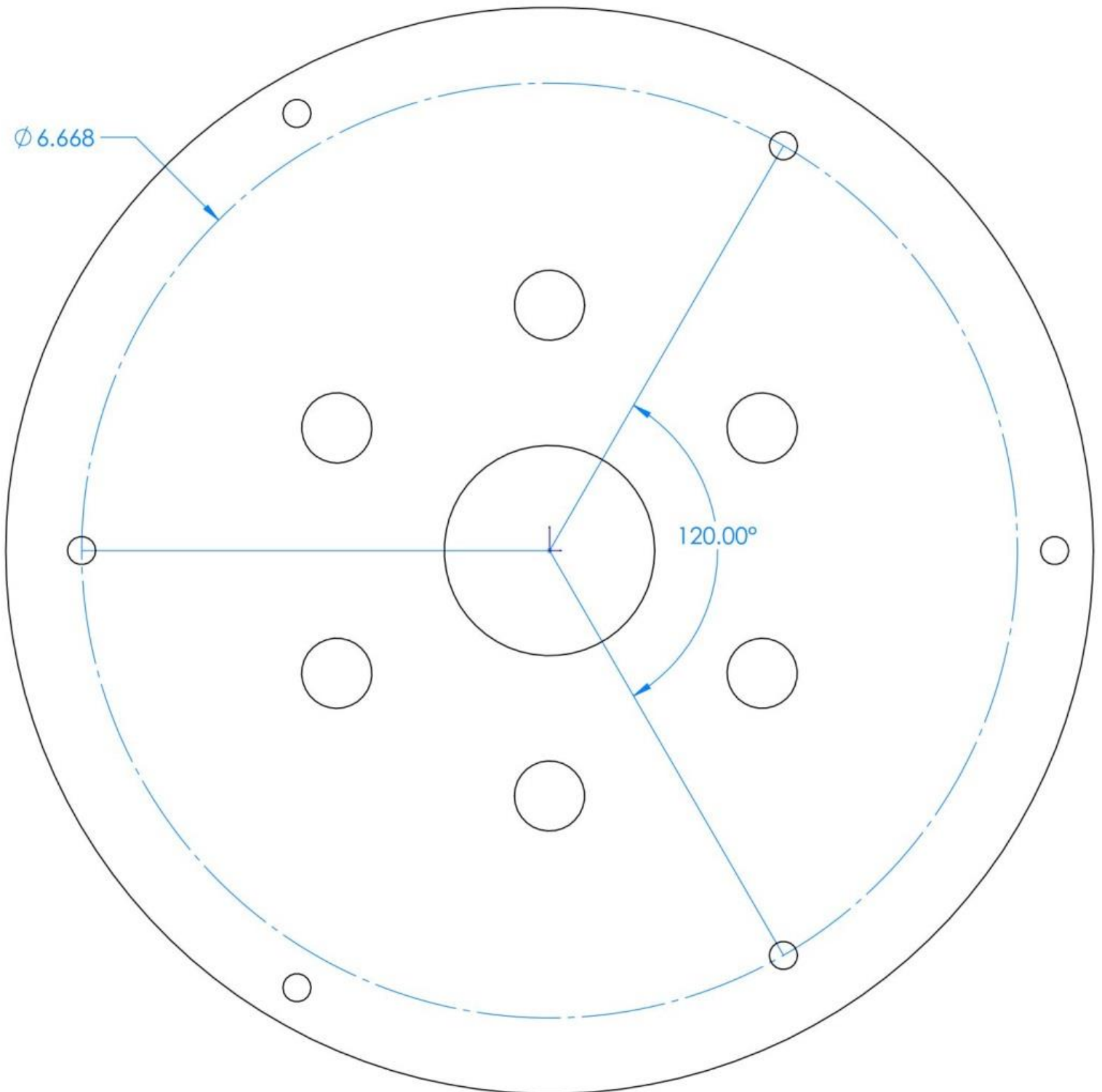

FIELD CALIBRATION

TR-525I & TR-525U & TR-525M

Absolutely accurate calibration can be obtained only with laboratory equipment, but an approximate field check can easily be made. The tipping bucket mechanism is a simple and highly reliable device. The transmitter must be located in a clear area, away from trees, buildings, etc. To obtain accurate readings, the unit must be mounted level and free of foreign material, dust, or other debris. The transmitter must be calibrated with the rate of flow of water through the tipping bucket mechanism under control.

A field calibration kit, the FC-500, is available from Texas Electronics, Inc. It consists of 3 rods, container, black bag, nozzle, cleaning pin for nozzle and instructions.

WIRING DIAGRAM

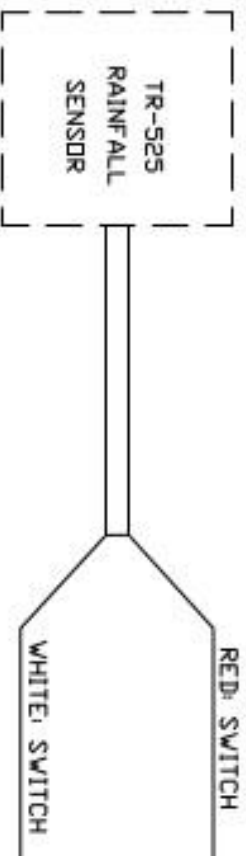

TYPICAL OUTPUT:

- TR-525i 0.01" tip (4.73mL)
- TR-525M 0.10mm per tip (4.73mL)
- TR-525USW 0.01" per tip (8.23mL)
- TR-525S 0.01" per tip (8.23mL)
- TR-4 0.01" per tip (1.95mL)

OPTIONAL OUTPUT

- TR-525i(metric) 0.2mm per tip (3.72mL)

Texas Electronics, Inc.			
The Gold Standard in Weather Instrumentation Since 1957			
TITLE		TR-525 RAINFALL SENSOR	
WIRING DIAGRAM			
SIZE	PSCM NO.	DMG NO.	REV
A		3001	A
SCALE			SHEET 1-1

Warranty

Texas Electronics, Inc. (hereafter TEI) warrants the equipment manufactured by it to be free from defects in material and workmanship. Upon return, transportation charges prepaid to TEI, within three (3) years of original shipment of sensors and one (1) year of original shipment of electronics, recorders and indicators, TEI will repair or replace, at its option, any equipment which it determines to contain defective material or workmanship, and will return said equipment to purchaser, F.O.B., TEI. Texas Electronics shall not be obligated however to repair or replace equipment which has been repaired by others, abused, improperly installed, altered or otherwise misused or damaged in any way. TEI will not be responsible for any dismantling, re-assembly, or reinstallation charges.

This warranty is in lieu of all other warranties, expressed or implied. TEI shall not be liable for any special, indirect, incidental or consequential damages claimed in connection with any rescission of this agreement by purchaser.