

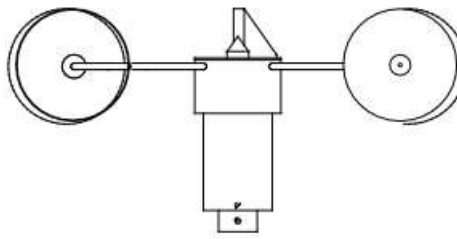

**TV-110-L320
TV-110-L320-A
Wind Speed Sensor
User's Manual**



Model TV-110-L320 Wind Speed Sensor

DESCRIPTION

The Texas Electronics, Inc. TV-110-L320 Wind Speed Sensor is a mechanical style anemometer that measures the horizontal velocity of wind. This unit is designed to meet or exceed all the EPA's Prevention of Significant Deterioration (PSD) requirements.

The TV-110-L320 wind speed sensor is a freestanding device for measuring air velocity. The sensor consists of a lightweight 3-cup anemometer, which is mechanically coupled to a 20-slot disc located within the sensor housing. A light beam, produced by an infrared light emitting diode (LED), passes through the slotted disc and falls upon a light-detecting transistor. The transistor switches on and off 20 times for each revolution of the cup assembly. Therefore a pulsed output is produced which is proportional to wind speed.

SPECIFICATIONS

	<u>TV-110-L320</u>	<u>TV-110-L320-A</u>
Operating Range:	0-100 mph	0-100 mph
Signal Presentation:	frequency, pulsed output light chopper. The 20-slot disc produces the following linear repetition rate.	frequency, pulsed output light chopper. The 20-slot disc produces the following linear repetition rate.
	10 RPM = 1 MPH = 200 pulses/min.	4 mA = 0 mph
	100 RPM = 10 MPH = 2,000 pulses/min.	20 mA = 100 mph
	1000 RPM = 100 MPH = 20,000 pulses/min.	
Excitation:	+5.0 VDC @ 5mA (typical) (Other voltages available upon request)	10-36 VDC
Performance:		
Accuracy:	+/- 1.0 mph (0.45 m/s) over entire range +/- 0.6 mph (0.25 m/s) at less than 11.2 mph (5.0 m/s)	+/- 1.0 mph (0.45 m/s) over entire range +/- 0.6 mph (0.25 m/s) at less than 11.2 mph (5.0 m/s)
Distance Constant:	> 16.5' (5.0 m)	>16.5' (5.0 m)
Starting Threshold:	1.1 mph (0.5 m/s)	1.1 mph (0.5 m/s)
Environmental:		
Operational Envelope:	0-135 mph (0 to 60 m/s)	0-135 mph (0 to 60 m/s)

Temperature: -40 to 160° F (-40 to 70° C)

Relative Humidity: 0-100%

Physical:

Height: 6.5" (16.5 cm)

Cup Diameter: 3.25" (8.25 cm)

Cup Wheel Diameter: 12.5" (32 cm)

Finish: Gold Anodized Aluminum

Cable: 60', 22 Gauge 3 conductor

Weight: 1 lb. (0.45 kg) less cable

Bearings: APEC 3 or better

Mounting Pole: 0.75" O.D. (1.9 cm)

Warranty: 3 years

FEATURES & BENEFITS

- Superior low starting threshold
- No plastic parts for extremely long life
- Precision stainless steel bearings for stability and repeatability
- Crossarm included with purchase of matching wind direction sensor
- Easy installation and maintenance
- Over 25 years in production
- Lightweight and rugged anodized aluminum exterior

INSTALLATION & MAINTENANCE

Installation consists of attaching the unit to a mast via the supplied mounting pole. If a crossarm is used, the entire unit can be bolted to a mast or attached via U-bolts.

The sensor is dynamically calibrated at the factory and due to the nature of its operation should not require field calibration. Field maintenance should include occasional cleaning of the cup assembly and inspection of the internal mechanism to make sure it is free from insects and debris. In some applications users may need to occasionally verify and document sensor accuracy with a synchronous test motor. Possible bearing and photo detector replacement every three to five years is recommended to maintain low starting threshold.

ORDERING INFORMATION

Model #	Description
TV-110-L320	Wind Speed Sensor, Medium Industrial (Specify supply voltages other than 5VDC)
TV-110-L320-A	Wind Speed Sensor, 4-20 mA <i>* Sensor is designed to work with TD-106-5D wind direction sensor.</i>

Optional Parts / Accessories

T-8011M Synchronous motor for calibration

PROPER EXPOSURE OF METEOROLOGICAL INSTRUMENTS

The following generally recognized guidelines depict ideal sensor mounting locations. These guidelines are only suggestions to aid the user in selecting optimum representative sampling locations for a particular sensor.

Reference was made to US Weather Bureau Installation criteria in preparing this data (See Reference 1).

WIND EQUIPMENT:

So far as available sites permit, wind sensors should be placed above the ground on a freely-exposed tower (20 feet or higher) and over terrain that is relatively level and free from obstructions to wind flow. When a compromise must be made, sensing units should be exposed at least 12 feet above any obstruction within 100 feet and at least as high as any obstruction within 100 to 200 feet of the wind equipment. Support towers or masts should not be of such bulk or shape as to create an appreciable obstruction to wind flow. Avoid sites where local obstructions may create up-or-down drafts, eddy currents or jet-flow effects. When sensors are roof-mounted, they should be installed at least 10 feet (or more) from the roof surface, depending upon the particular installation site. Turbulence and other local effects can be reduced somewhat by mounting sensors on the upwind end of the building (the end of the building exposed to the most common local prevailing winds). Horizontal-mount booms that extend from existing towers should be fabricated so that sensors will extend a distance of 5 to 10 feet from the tower assembly (dependent on tower thickness).

Wind direction sensors are oriented upon installation in reference to either true north or magnetic north. True north is obtained by applying a local magnetic variation correction factor to a magnetic north compass indication (magnetic variation for a particular locality is obtainable from the nearest Weather Bureau Branch Office). Indicator readings for a true north sensor orientation will then be in terms of true geographic compass points. All U.S. Weather Bureau surface wind data used for observational network reporting purposes and general public use is given in reference to this true north format. Indicator readings for a magnetic north sensor orientation will be in terms of actual readings as would be obtained from directly viewing a magnetic compass instrument. Wind direction data at Federal Aviation Agency and other aircraft reporting facilities (for direct control tower-to-pilot utilization) is always made in reference to this magnetic north format.

WIRING DIAGRAM

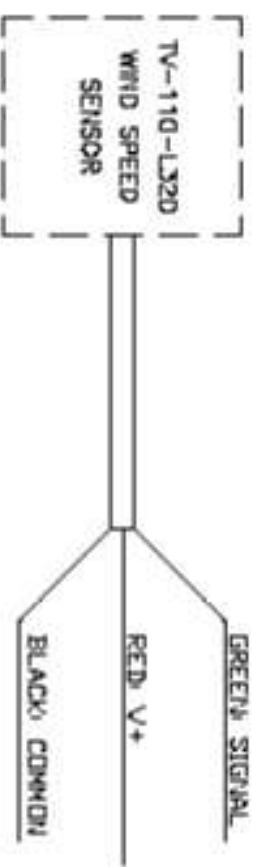

TYPICAL RANGE
0-100 MPH

OUTPUT
1000 RPM = 100 MPH = 20K pulses/min

Texas Electronics, Inc.

THE GOLD STANDARD IN WEATHER INSTRUMENTATION SINCE 1967



TITLE TV-110-L320 WIND SPEED SENSOR
WIRING DIAGRAM

SIZE	FORM NO.	DWG. NO.	REV.
A		3018	A
SCALE	SHEET 1 - 1		

WIRING DIAGRAM

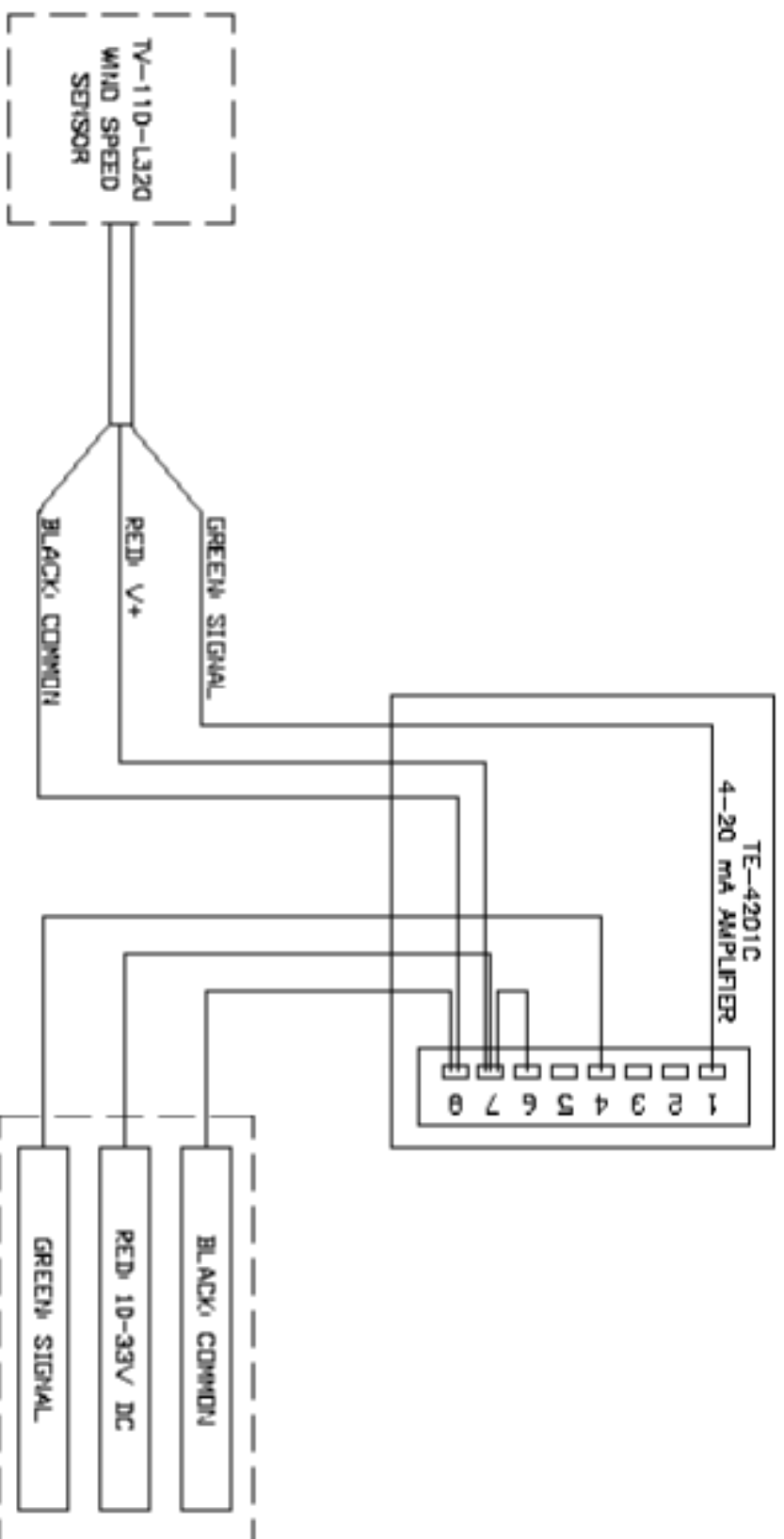

TYPICAL RANGE
0-100 MPH

OUTPUT
4 to 20 mA

Texas Electronics, Inc.			
The Gold Standard in Weather Instrumentation Since 1967			
			
TITLE TV-110-L320A WIND SPEED SENSOR			
SIZE A	FSOM NO.	OMG NO. 3017	REV A
SCALE		SHEET 1-1	

WIRING DIAGRAM

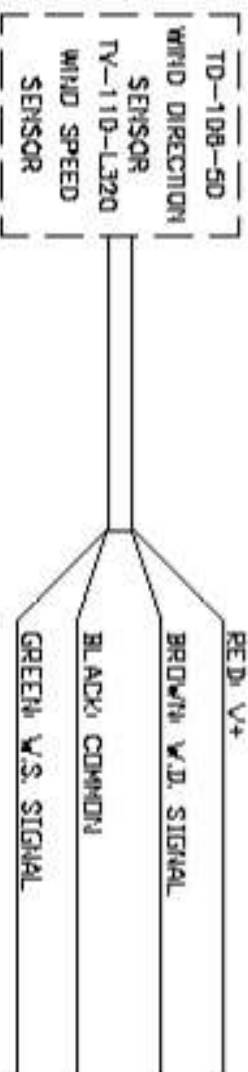

TYPICAL RANGE

WIND DIRECTION: 0-360° Mech., 0-357° Elect.
 WIND SPEED: 0-100 MPH

OUTPUT

WIND DIRECTION: 10K OHM POTENTIOMETER
 WIND SPEED: 1000 RPM = 100 MPH = 20k pulses/min

Texas Electronics, Inc.			
The Gold Standard in Weather Instrumentation Since 1957			
			
TITLE		TD-106 WIND DIRECTION & TV-110-L320 WIND SPEED WIRING DIAGRAM	
SIZE	FROM ID.	ENG. NO.	REV.
A		3014	A
SCALE			SHEET 1-1

WIRING DIAGRAM

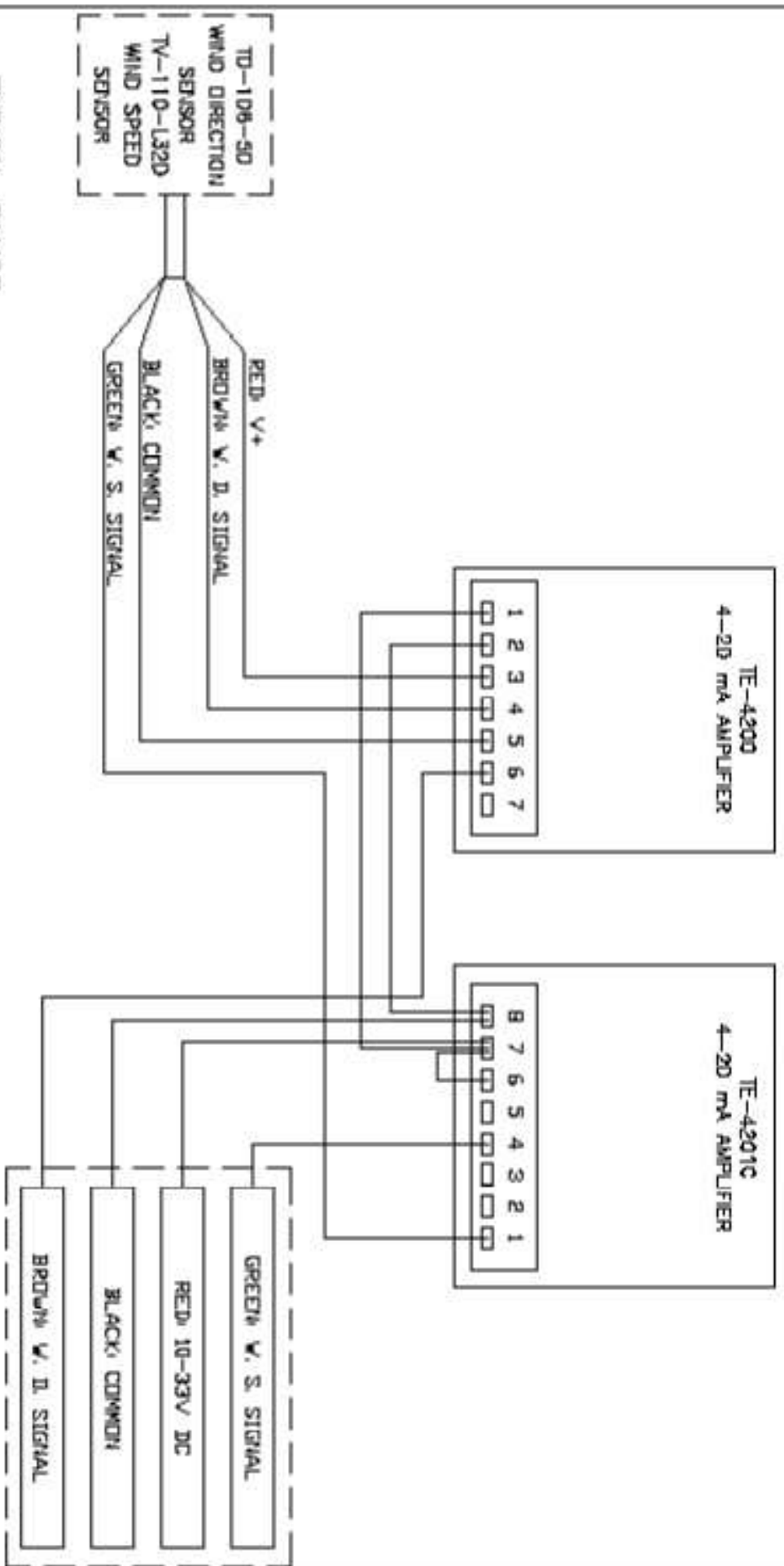

TYPICAL RANGE
 WIND SPEED: 0-100 MPH
 WIND DIRECTION: 0-355° ELECTRICAL, 0-360° MECH.
OUTPUT
 4 to 20 mA

Texas Electronics, Inc.			
The Gold Standard in Weather Instrumentation Since 1967			
			
TITLE		TD-106A WIND DIRECTION & TV-110-L320A WIND SPEED	
SIZE	FORM NO.	DATE NO.	REV
A		3013	A
SCALE		SHEET 1-1	

Warranty

Texas Electronics, Inc. (hereafter TEI) warrants the equipment manufactured by it to be free from defects in material and workmanship. Upon return, transportation charges prepaid to TEI, within three (3) years of original shipment of sensors and one (1) year of original shipment of electronics, recorders and indicators, TEI will repair or replace, at its option, any equipment which it determines to contain defective material or workmanship, and will return said equipment to purchaser, F.O.B., TEI. Texas Electronics shall not be obligated however to repair or replace equipment which has been repaired by others, abused, improperly installed, altered or otherwise misused or damaged in any way. TEI will not be responsible for any dismantling, re-assembly, or reinstallation charges.

This warranty is in lieu of all other warranties, expressed or implied. TEI shall not be liable for any special, indirect, incidental or consequential damages claimed in connection with any rescission of this agreement by purchaser.